

# AIR PREPARATION UNITS LUBRICATOR series

**Kushako**

## Lubricator details :

### Features :

- Suitable for modular mountings.
- Fog / Mist Type
- Fine adjustment of lubrication.
- Lubrication proportional to flow.

### Precautions :

- Note the direction of flow before installation & connect pipe accordingly.
- Nipples of taper threads to be used with teflon tape. Ensure teflon tape does not enter the unit during tightening. Nipples of straight threads to be used with sealing washer.
- Flush piping for dirt, dust, rust & other foreign particles.
- Install in clean atmosphere.
- Oil may be filled when under pressure. However it is recommended to vent the air completely before filling the oil.



## Technical Specifications:

Model	LUB-2016
Medium	Compressed air - Filtered
Port Size	G1/2 BSP ( F )
Bowl capacity (ml)	152
Flow rate ( Ltr / Min )	5650
Maximum supply pr. (bar)	10
Recommended oil	ISO VG 32 (Servo System 32)
Bowl material	Polycarbonate
Ambient / Medium temp.	5° - 50° C
Installation	Vertical (As in the picture)
Materials of construction	Al, Brass, Steel, Polycarbonate, SS, Nitrile
Optional accessories	Clamp, Modular mounting kit
Weight (Kg)	0.529

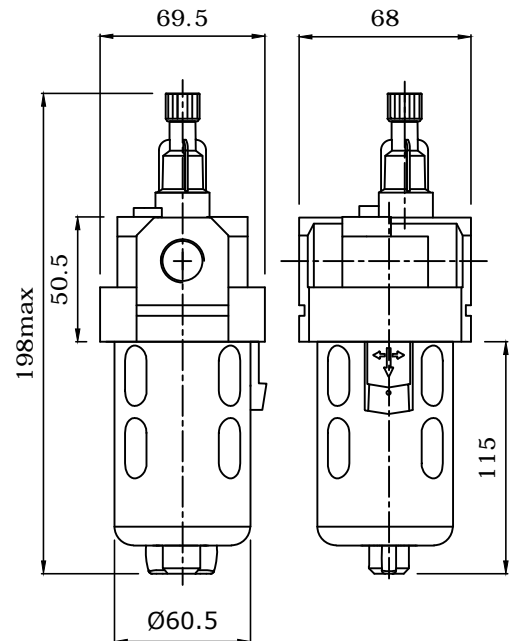

- Supply pressure 6 bar , pressure drop p= 0.5 bar (for standard models)

Manufactured by :

***Kushako India***

Office : 490, Narayan Peth, Opp. Pune Marathi Granthalaya, Pune - 411030. (Maharashtra), Website : [www.kushakoindia.com](http://www.kushakoindia.com)

Works : Sr.No. 25/1A, Village Nanded, Sinhgad Road, Tal - Haveli, Dist. Pune -411041

Tel. No : 901169077 / 7620674777

E-mail : [kushako.india@gmail.com](mailto:kushako.india@gmail.com) / [kushakoindia1992@gmail.com](mailto:kushakoindia1992@gmail.com)

**Kushako**